



**Hubs & Wheels**

REVISED 09/23

**PARTS** CATALOGUE  
SECTION 9



***Westward has the part!***

## INDEX

|   |                  |                                |      |
|---|------------------|--------------------------------|------|
| Casters .....                                 | 9-14             | Hub Kits, Unassembled .....    | 9-7  |
| Dust Caps.....                                | 9-9              | Seals.....                     | 9-8  |
| Grease Seals.....                             | 9-9              | Spindles.....                  | 9-8  |
| Hubs  |                  | Spindle Nuts .....             | 9-8  |
| 10 Bolt, 11.25" Bolt Circle, 8.69" Pilot..... | 9-6, 9-12        | Spindle Washers .....          | 9-8  |
| 4 Bolt, 5" Bolt Circle, 3.62" Pilot .....     | 9-1, 9-11        | Utility Wheels.....            | 9-13 |
| 5 Bolt, 5.50" Bolt Circle, 4" Pilot .....     | 9-3, 9-11        | Wheels                         |      |
| 6 Bolt, 6" Bolt Circle, 4.62" Pilot .....     | 9-4 to 9-5, 9-11 | 14" Light Duty Concave.....    | 9-1  |
| 8 Bolt, 8" Bolt Circle, 6" Pilot .....        | 9-5 to 9-6       | 14" Medium Duty .....          | 9-3  |
| For up to 12" Diameter Wheels .....           | 9-2              | 14" Standard Convex .....      | 9-4  |
| For 14" Diameter Wheels .....                 | 9-1 to 9-5       | 15" Agricultural Duty .....    | 9-5  |
| For 15" Diameter Wheels .....                 | 9-1 to 9-6       | 15" Light Duty Concave.....    | 9-1  |
| For 16" Diameter Wheels .....                 | 9-4 to 9-6       | 15" Medium Duty.....           | 9-3  |
| Air Seeder .....                              | 9-12             | 15" Standard Convex .....      | 9-4  |
| CCIL, To Fit.....                             | 9-12             | 16" Standard Convex .....      | 9-4  |
| Chisel Plow.....                              | 9-12             | Flat Free .....                | 9-13 |
| Complete .....                                | 9-7              | Plastic.....                   | 9-13 |
| Concord, To Fit.....                          | 9-11             | Rib .....                      | 9-13 |
| Flexicoil, To Fit.....                        | 9-12             | Wheel Barrow.....              | 9-13 |
| Kits with Components.....                     | 9-7              | Utility.....                   | 9-13 |
| Melroe, To Fit.....                           | 9-11             | Wheel Bolts .....              | 9-10 |
| Morris, To Fit.....                           | 9-12             | Wheel Offset Explanation ..... | 9-2  |
| Special.....                                  | 9-11 to 9-12     | Wheel Stud Nuts.....           | 9-10 |
| Versatile, To Fit.....                        | 9-11             |                                |      |

**CTD HUBS, WHEELS & SPINDLES**

**14" & 15" Diameter Light Duty Concave Implement Wheels**

**4 BOLT, 5" BOLT CIRCLE, 3.62" PILOT**

| PART NO.  | RIM       | OFFSET | CAPACITY (lbs.) |
|-----------|-----------|--------|-----------------|
| HUB14X5X4 | 14 x 5 KB | -.38   | 1250            |
| HUB15X5X4 | 15 x 5 KB | -.38   | 1250            |

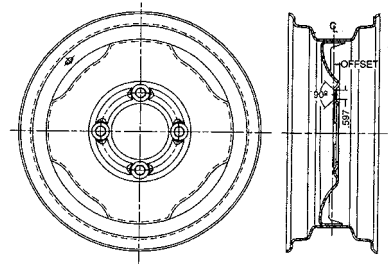

**Hubs & Component Parts for 14" & 15" Diameter Light Duty Wheels**

**4 BOLT, 5" BOLT CIRCLE, 3.62" PILOT**

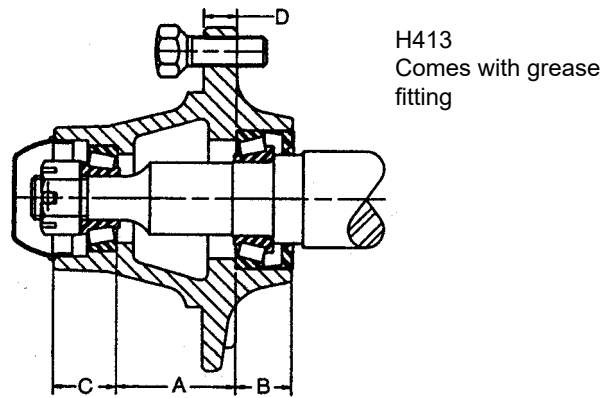
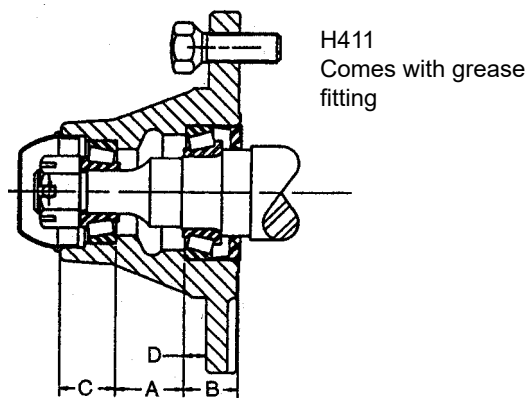

| HUB NO.   | BEARING NO. |           |            |            |            |            | PARTS NO. |            |             | A    | B   | C    | D   | *CAP lbs. | SPINDLE  |
|-----------|-------------|-----------|------------|------------|------------|------------|-----------|------------|-------------|------|-----|------|-----|-----------|----------|
|           | INNER CUP   | OUTER CUP | INNER CONE | INNER BORE | OUTER CONE | OUTER BORE | DUST CAP  | WHEEL BOLT | GREASE SEAL |      |     |      |     |           |          |
| HUBH411-3 | LM67010     | LM11910   | LM67048    | 1.25       | LM11949    | .75        | DC12      | WB10       | SE11        | 1.18 | .93 | .93  | .37 | 1250      | S411-A09 |
| HUBH413-6 | LM67010     | LM11910   | LM67048    | 1.25       | LM11949    | .75        | DC24      | WB10       | SE11        | 2.00 | .93 | 1.06 | .56 | 1500      | S511-A01 |

Hub capacities based on .38 Negative Offset, 20,000 mile minimum bearing life at tractor speed (20MPH) and 14,000 PSI. Maximum Fiber Stress on the spindle. Hubs include parts in shaded areas only.

## CTD HUBS, WHEELS & SPINDLES

### Wheel Offset Explanation

**OFFSET:** (as defined by S.A.E. standards) is the distance between mounting face of the flange and the rim centerline.

**POSITIVE OFFSET: (INSET)** This distance is termed positive when the mounting face is outboard of the rim centerline.

**NEGATIVE OFFSET: (OUTSET)** This distance is termed negative when the mounting face is inboard of the rim centerline.

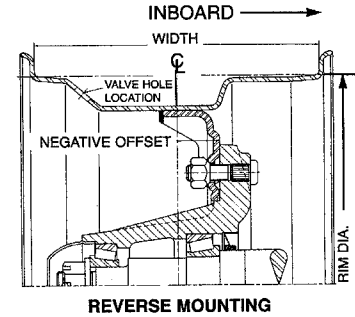
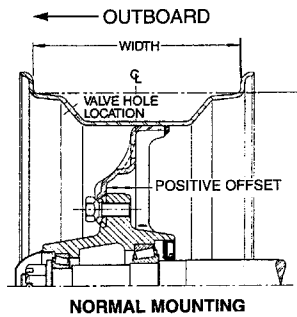

### Hubs & Components for up to 12" Diameter Wheels

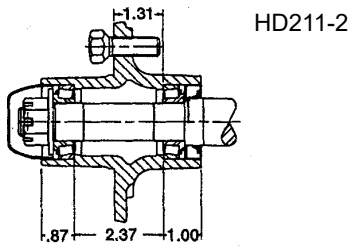

| HUB ORDER NO. | NO. OF BOLTS | BOLT CIRCLE | PILOT | INNER CUP | OUTER CUP | INNER CONE | OUTER CONE | DUST CAP | WHEEL BOLT | GREASE SEAL | *CAP lbs. | SPINDLE  |
|---------------|--------------|-------------|-------|-----------|-----------|------------|------------|----------|------------|-------------|-----------|----------|
| HUBHD211-2    | 4            | 4.00        | 2.50  | L44610    | L44610    | L44643     | L44643     | DC11     | WB10       | SE10        | 1250      | S210-A36 |

NOTE: HD211-2 & HD213-2 hub capacity based on zero offset. Maximum wheel diameter 12". Hubs include parts in shaded areas only.

**CTD HUBS, WHEELS & SPINDLES**

**14" & 15" Diameter Medium Duty Implement Wheels**

**5 BOLT, 5.50" BOLT CIRCLE, 4" PILOT**

| PART NO.  | RIM       | OFFSET | CAPACITY (lbs.) |
|-----------|-----------|--------|-----------------|
| HUB15X5X5 | 15 X 5 KB | -.25   | 2000            |
| HUB15X6X5 | 15 x 6 LB | -.25   | 2000            |
| HUB15X8X5 | 15 x 8 LB | -.25   | 2000            |

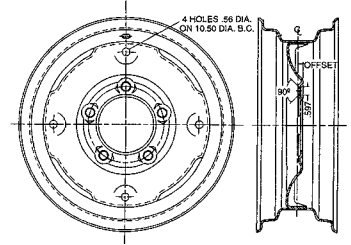

**Hubs & Component Parts for 14" & 15" Diameter Medium Duty Wheels**

**5 BOLT, 5.50" BOLT CIRCLE, 4" PILOT**

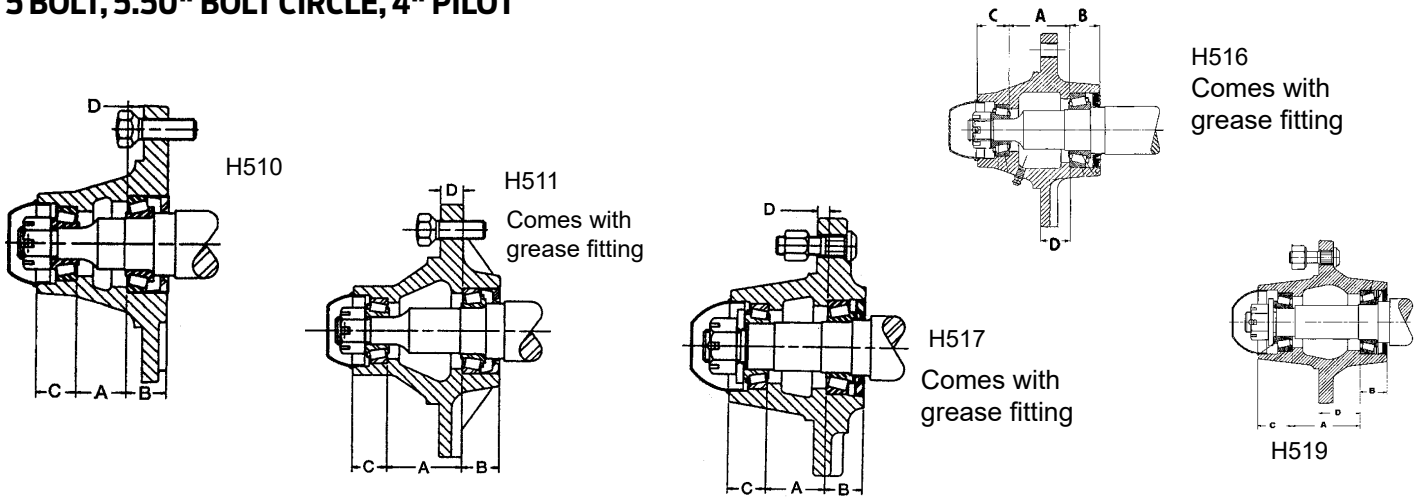

| HUB NO.   | BEARING NO. |           |            |            |            |            | PARTS NO. |              |             | A    | B     | C     | D    | *CAP lbs. | SPINDLE  |
|-----------|-------------|-----------|------------|------------|------------|------------|-----------|--------------|-------------|------|-------|-------|------|-----------|----------|
|           | INNER CUP   | OUTER CUP | INNER CONE | INNER BORE | OUTER CONE | OUTER BORE | DUST CAP  | WHEEL BOLT   | GREASE SEAL |      |       |       |      |           |          |
| HUBH510   | LM67010     | LM11910   | LM67048    | 1.25       | LM11949    | .75        | DC12      | WB10         | SE11        | 1.18 | .93   | .93   | .37  | 1250      | S411-A09 |
| HUBH511-2 | LM67010     | LM11910   | LM67048    | 1.25       | LM11949    | .75        | DC12      | WB10         | SE11        | 2.03 | 1.0   | .93   | .63  | 1800      | S511-A01 |
| HUBH517-2 | LM48510     | LM67010   | LM48548    | 1.37       | LM67048    | 1.25       | DC13      | WB16<br>WB11 | SE13        | 1.56 | 1.0   | 1.0   | .31  | 2760      | S517-A02 |
| HUBH516   | LM48510     | LM11910   | LM48548    | 1.37       | LM11949    | .75        | DC12      | WB10         | SE14        | 2.03 | 1.0   | 1.09  | 1.0  | 1840      | S516-A03 |
| HUBH519   | LM13621     | LM15250   | LM13685    | 1.50       | LM15118    | 1.189      | DC15      | WB16<br>WB11 | SE13X       | 2.87 | 1.125 | 1.437 | 1.75 | 1680      | S519     |

Hub capacities based on .25 negative offset 20,000 mile minimum bearing life at tractor speed (20 mph) and 14,000 PSI. Maximum Fiber Stress on the spindle. Hubs include parts in shaded areas only.

## CTD HUBS, WHEELS & SPINDLES

### 14" & 15" & 16" Diameter Standard Convex Implement Wheels

#### 6 BOLT, 6" BOLT CIRCLE, 4.62" PILOT

| PART NO.   | RIM         | OFFSET | CAPACITY (lbs.) |
|------------|-------------|--------|-----------------|
| HUB15X6X6  | 15 x 6 LB   | + 1.12 | 3000            |
| HUB15X8X6  | 15 x 8 LB   | + 1.12 | 3000            |
| HUB15X10X6 | 15 x 10 LBH | + 1.12 | 3800            |
| HUB16X6X6  | 16 x 6 LBH  | + 1.12 | 3800            |
| HUB16X8X6  | 16 x 8 LBH  | + 1.12 | 3800            |

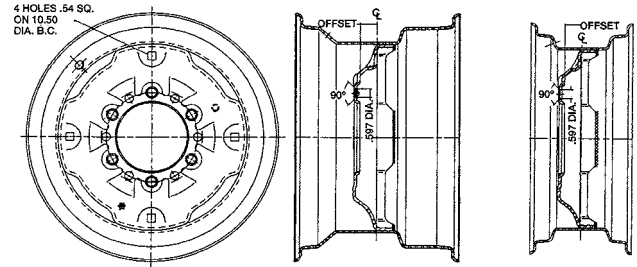

### Hubs & Component Parts for 14" & 15" & 16" Convex Implement Wheels

#### 6 BOLT, 6" BOLT CIRCLE, 4.62" PILOT

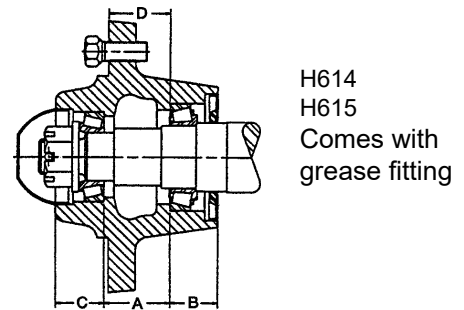
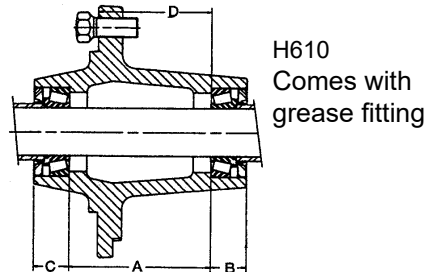
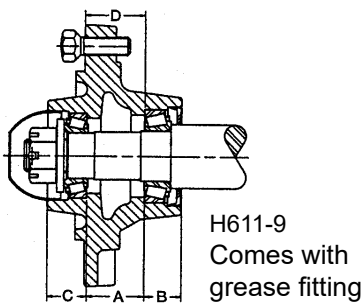

| HUB NO.     | BEARING NO. |           |            |            |            |            | PART NO. |            |             | A    | B    | C    | D    | *CAP lbs. | SPINDLE     |
|-------------|-------------|-----------|------------|------------|------------|------------|----------|------------|-------------|------|------|------|------|-----------|-------------|
|             | INNER CUP   | OUTER CUP | INNER CONE | INNER BORE | OUTER CONE | OUTER BORE | DUST CAP | WHEEL BOLT | GREASE SEAL |      |      |      |      |           |             |
| HUBH610-3   | LM48510     | LM48510   | LM48548    | 1.37       | LM48548    | 1.37       | -        | WB12       | SE14        | 4.00 | 1.00 | 1.00 | 3.18 | 3800      | -           |
| HUBH611-1   | LM29710     | LM67010   | LM29749    | 1.50       | LM67048    | 1.25       | DC13     | WB10       | SE14        | 1.56 | 1.00 | 1.06 | 1.62 | 3600      | S611-A04    |
| HUBH611-3   | LM48510     | LM67010   | LM48548    | 1.375      | LM67048    | 1.25       | DC13     | WB10       | SE28        | 1.56 | 1.00 | 1.06 | 1.62 | 3600      | S611-A15    |
| HUBH611-9   | LM29710     | LM67010   | LM29749    | 1.50       | LM67048    | 1.25       | DC13     | WB10       | SE13        | 1.56 | 1.00 | 1.06 | 1.62 | 3600      | S611-A04    |
| HUBH611-1-J | JL69310     | LM67010   | JL69349    | 1.50       | LM67048    | 1.25       | DC13     | WB10       | SE14        | 1.56 | 1.00 | 1.06 | 1.62 | 3600      | S611-1-JA04 |
| HUBH614-1   | LM603011    | LM48510   | LM603049   | 1.78       | LM48548    | 1.375      | DC15     | WB12       | SE16        | 1.75 | 1.37 | 1.37 | 1.62 | 5000      | S614-A05    |
| HUBH615-1   | LM603011    | LM48510   | LM603049   | 1.78       | LM48548    | 1.375      | DC15     | WB12       | SE29        | 1.75 | 1.37 | 1.37 | 1.62 | 5000      | S614-A05    |
| HUBH618-3   | 25520       | LM48548   | 25580      | 1.750      | LM48548    | 1.375      | DC15     | WB12       | SE30        | 2.53 | 1.53 | 1.06 | 1.09 | 6000      | S618-A17    |

Hub capacities based on 1.12 positive offset 20,000 mile minimum bearing life at tractor speed (20mph) and 14,000 PSI. Maximum fiber stress on the spindle. Hubs include parts in shaded areas only.

**CTD HUBS, WHEELS & SPINDLES**

**Hubs & Component Parts for 14", 15" & 16" Convex Implement Wheels**

**6 BOLT, 6" BOLT CIRCLE, 4.62" PILOT**

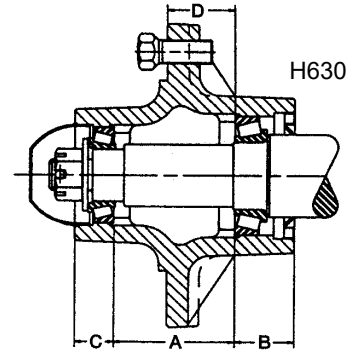
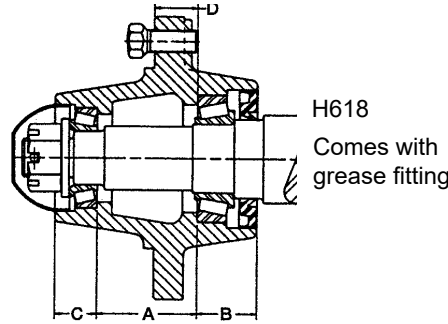
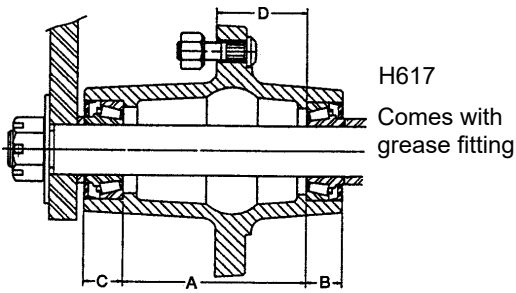

| HUB NO.   | BEARING NO. |           |            |            |            |            | PART NO. |              |             | A    | B    | C    | D    | *CAP lbs. | SPINDLE  |
|-----------|-------------|-----------|------------|------------|------------|------------|----------|--------------|-------------|------|------|------|------|-----------|----------|
|           | INNER CUP   | OUTER CUP | INNER CONE | INNER BORE | OUTER CONE | OUTER BORE | DUST CAP | WHEEL BOLT   | GREASE SEAL |      |      |      |      |           |          |
| HUBH617-1 | 13621       | 13621     | 13686      | 1.50       | 13686      | 1.50       | -        | WB16<br>WB11 | SE24        | 5.00 | 1.06 | 1.00 | 3.37 | 3500      | -        |
| HUBH618   | 25520       | LM48510   | 25580      | 1.75       | LM48548    | 1.37       | DC15     | WB12         | SE30        | 2.53 | 1.53 | 1.06 | 1.09 | 6000      | S618-A17 |
| HUBH630   | LM501310    | LM67010   | LM501349   | 1.62       | LM67048    | 1.25       | DC13     | WB12         | SE44        | 2.84 | 1.43 | .93  | 1.59 | 3500      | S630-A01 |

Hub capacities based on 1.12 positive offset 20,000 mile minimum bearing life at tractor speed (20mph) and 14,000 PSI. Maximum fiber stress on the spindle. Hubs include parts in shaded areas only.

**15" & 16" Diameter Agricultural Implement Wheels**

**8 BOLT, 8" BOLT CIRCLE, 6" PILOT**

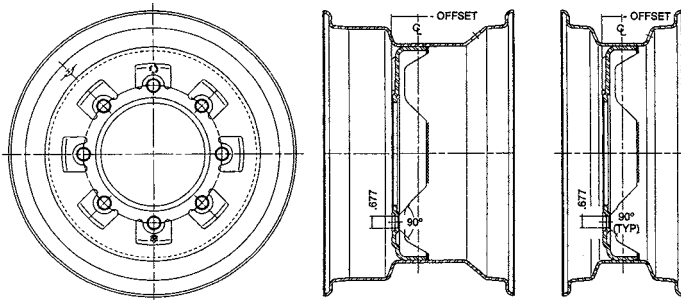

| PART NO.   | RIM        | OFFSET* | CAPACITY (lbs.) |
|------------|------------|---------|-----------------|
| HUB15X8X8  | 15 x 8 LB  | -1.50   | 5000            |
| HUB15X10X8 | 15 x 10 LB | +38     | 5000            |
| HUB16X8X8  | 16 x 8 LBH | -1.50   | 5000            |
| HUB16X10X8 | 16 x 10 LB | -1.50   | 5000            |

\*Other offsets available.

## CTD HUBS, WHEELS & SPINDLES

### Hubs & Component Parts for 15" & 16" Agricultural Wheels

#### 8 BOLT, 8" BOLT CIRCLE, 6" PILOT for Agricultural Applications

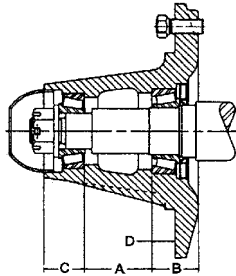

**H811**  
Comes with  
grease fitting

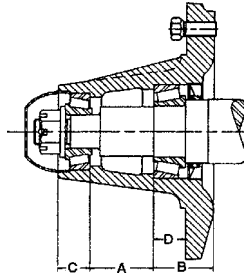

**H812**  
Comes with  
grease fitting

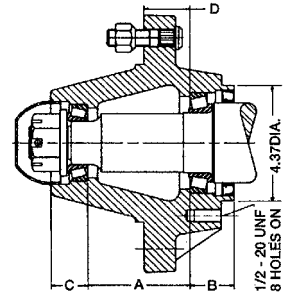

**H817**  
Comes with  
grease fitting

| HUB NO.     | BEARING NO. |           |            |            |            |            | PART NO. |            |             | A    | B    | C    | D    | *CAP lbs. | SPINDLE  |
|-------------|-------------|-----------|------------|------------|------------|------------|----------|------------|-------------|------|------|------|------|-----------|----------|
|             | INNER CUP   | OUTER CUP | INNER CONE | INNER BORE | OUTER CONE | OUTER BORE | DUST CAP | WHEEL BOLT | GREASE SEAL |      |      |      |      |           |          |
| HUBH811     | 25520       | 25821     | 25590      | 1.79       | 25877      | 1.37       | DC17     | WB12       | SE16        | 2.50 | 1.75 | 1.50 | .87  | 5050      | S811     |
| HUBHD812-10 | 3720        | 2720      | 3780       | 2.00       | 2790       | 1.31       | DC17     | WB12       | SE17        | 2.44 | 2.28 | 1.21 | 1.21 | 6100      | S812-A27 |
| HUBH817-3   | 382A        | LM5013-10 | 387AS      | 2.25       | LM50-1349  | 1.62       | DC26     | WB46       | SE42        | 3.75 | 1.62 | 1.37 | 1.68 | 7500      | S817-A03 |
|             |             |           |            |            |            |            |          | WB18       |             |      |      |      |      |           |          |

\*Hub capacities based on 1.50 negative offset (H817 series based on 1.12 positive offset). 20,000 mile minimum bearing life at tractor speed (20mph) and 14,000 PSI. Maximum fiber stress on the spindle. Hubs include parts in shaded areas only.

### Hubs & Component Parts for Agricultural Applications

#### 10 BOLT, 11.25" BOLT CIRCLE, 8.69" PILOT

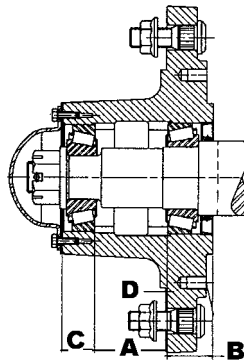

**H1010**  
Comes with  
grease fitting

| HUB NO.       | BEARING NO. |           |            |            |            |            | PART NO. |            |             | A    | B    | C    | D    | *CAP lbs. | SPINDLE   |
|---------------|-------------|-----------|------------|------------|------------|------------|----------|------------|-------------|------|------|------|------|-----------|-----------|
|               | INNER CUP   | OUTER CUP | INNER CONE | INNER BORE | OUTER CONE | OUTER BORE | DUST CAP | WHEEL BOLT | GREASE SEAL |      |      |      |      |           |           |
| HUBH1010-13** | 39520       | 453A      | 39585      | 2.50       | 460        | 1.75       | DC27     | WB51       | SE48        | 2.81 | 1.75 | 1.25 | 0.06 | 12,000    | S1010-A02 |
|               |             |           |            |            |            |            |          | WB52       |             |      |      |      |      |           |           |

\*Hub capacities based on zero offset, 20,000 mile minimum bearing life at tractor speed (20mph) and 14,000 PSI. Maximum fiber stress on the spindle.

\*\*For brake application. Hubs include parts in shaded areas only.



**CTD HUBS, WHEELS & SPINDLES**

**HUB & Component Kits, Unassembled**

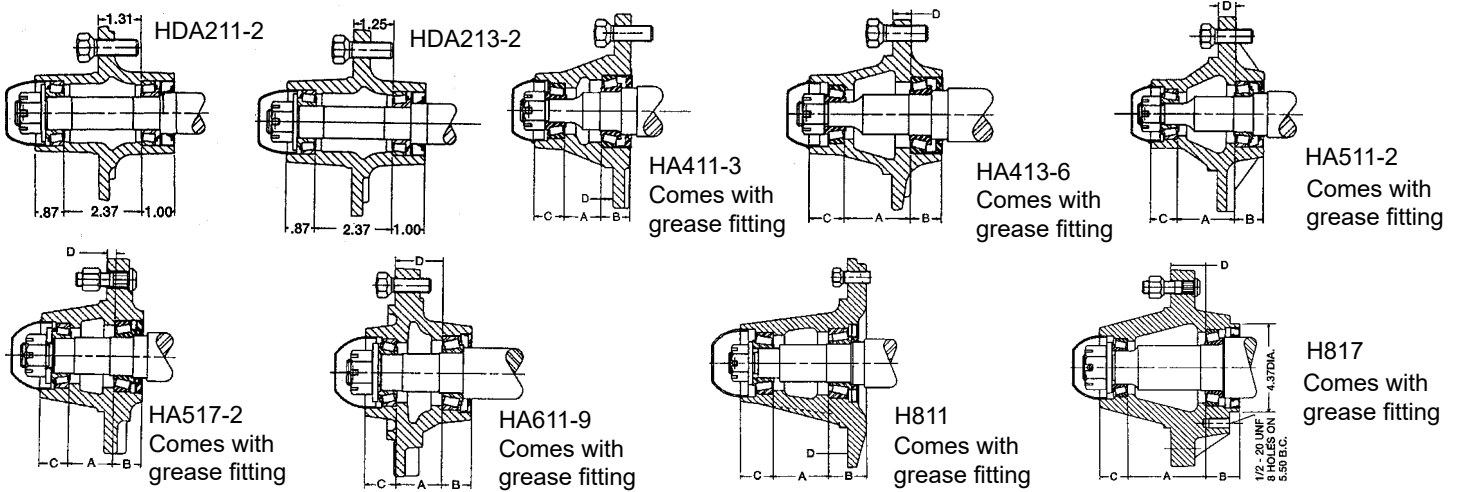

| HUB NO.       | BEARING NO. |           |            |            |            |            | PART NO. |              |             | A    | B    | C    | D    | *CAP lbs. | SPINDLE     |
|---------------|-------------|-----------|------------|------------|------------|------------|----------|--------------|-------------|------|------|------|------|-----------|-------------|
|               | INNER CUP   | OUTER CUP | INNER CONE | INNER BORE | OUTER CONE | OUTER BORE | DUST CAP | WHEEL BOLT   | GREASE SEAL |      |      |      |      |           |             |
| HUBHDA213-2   | L44610      | L44610    | L44643     | 1.00       | L44643     | 1.00       | DC11     | WB10         | SE10        | 2.37 | 1.0  | .87  | 1.25 | 1250      | S210-A36    |
| HUBHA411KIT-3 | LM67010     | LM11910   | LM67048    | 1.25       | LM11949    | .75        | DC12     | WB10         | SE11        | 1.18 | .93  | .93  | .37  | 1250      | S411-A09    |
| HUBHA413KIT-6 | LM67010     | LM11910   | LM67048    | 1.25       | LM11949    | .75        | DC24     | WB10         | SE11        | 2.00 | .93  | 1.06 | .56  | 1500      | S511-A01    |
| HUBHA510      | LM67010     | LM11910   | LM67048    | 1.25       | LM11949    | .75        | DC12     | WB10         | SE-11       | 1.18 | .93  | .93  | .37  | 1250      | S411-A09    |
| HUBHA511KIT-2 | LM67010     | LM11910   | LM67048    | 1.25       | LM11949    | .75        | DC12     | WB10         | SE11        | 2.03 | 1.00 | .93  | .63  | 1800      | S511-A01    |
| HUBHA517KIT-2 | LM48510     | LM67010   | LM48548    | 1.37       | LM67048    | 1.25       | DC13     | WB16<br>WB11 | SE13        | 1.56 | 1.00 | 1.00 | .31  | 2760      | S517-A02    |
| HUBHA611KIT-9 | LM29710     | LM67010   | LM29749    | 1.50       | LM67048    | 1.25       | DC13     | WB10         | SE13        | 1.56 | 1.00 | 1.06 | 1.62 | 3600      | S611-A04    |
| HUBHA614KIT-1 | LM603011    | LM48510   | LM603049   | 1.78       | LM48548    | 1.37       | DC15     | WB12         | SE16        | 1.75 | 1.37 | 1.37 | 1.62 | 5000      | S614-A05    |
| HUBHA615KIT-1 | LM603011    | LM48510   | LM603049   | 1.78       | LM48548    | 1.37       | DC15     | WB12         | SE29        | 1.75 | 1.37 | 1.37 | 1.62 | 5000      | S614-A05    |
| HUBHA618KIT-3 | 25520       | LM48548   | 25580      | 1.75       | LM48548    | 1.37       | DC15     | WB12         | SE-30       | 2.53 | 1.53 | 1.06 | 1.09 | 6000      | S618        |
| HUBHA811KIT   | 25520       | 25821     | 25590      | 1.79       | 25877      | 1.37       | DC17     | WB12         | SE16        | 2.50 | 1.75 | 1.50 | .87  | 5050      | S811        |
| HUBHA1010-3   | 33462       | 453A      | 33275      | 2.75       | 460        | 1.75       | DC27     | WB51         | SE67        | 2.81 | 1.75 | 1.25 | 0.06 | 15000     | S1010-3-A23 |

Note: HD211-2 & HD213-2 HUB capacity based on zero offset. Maximum wheel diameter 12". HA411-3 & HA413-6 HUB capacities based on .38 Negative Offset, 20,000 mile minimum bearing life at tractor speed (20MPH) and 14,000 PSI. Maximum Fiber Stress on the spindle. HA511-2, HA517-2, HA516, HA519 Hub capacities based on .25 negative offset 20,000 mile minimum bearing life at tractor speed (20 mph) and 14,000 PSI. Maximum Fiber Stress on the spindle. HA611-9, HA613-1, HA614-1, HA615-1 Hub capacities based on 1.12 positive offset 20,000 mile minimum bearing life at tractor speed (20mph) and 14,000 PSI. Maximum fiber stress on the spindle. HA811, HDA812-10, HA817-3 Hub capacities based on 1.50 negative offset (H817 series based on 1.12 positive offset) 20,000 mile minimum bearing life at tractor speed (20mph) and 14,000 PSI. Maximum fiber stress on the spindle. Kits do not include a spindle.

## CTD HUBS, WHEELS & SPINDLES

### Spindles

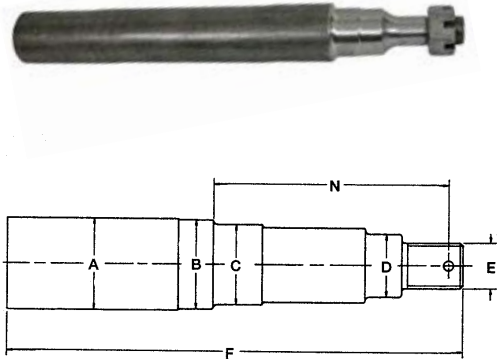

| SPINDLE SERIES  | A     | B    | C           | D           | E           | F     | N     |
|-----------------|-------|------|-------------|-------------|-------------|-------|-------|
| HUBS210-A36     | 1.25  | 1.25 | 1.000/.998  | 1.000/.988  | 3/4-16UNF   | 9     | 4.15  |
| HUBS411-A09     | 1.50  | 1.50 | 1.250/1.248 | .750/.748   | 3/4-16UNF   | 10    | 2.93  |
| HUBS411-A11     | 1.50  | 1.50 | 1.250/1.248 | .750/.748   | 3/4-16UNF   | 12    | 2.93  |
| HUBS411-A47     | 1.50  | 1.50 | 1.250/1.248 | .750/.748   | 3/4-16UNF   | 13.5  | 2.93  |
| HUBS511-A01     | 1.62  | 1.62 | 1.250/1.248 | .750/.748   | 3/4-16UNF   | 10    | 3.81  |
| HUBS511-A07     | 1.62  | 1.50 | 1.250/1.248 | .750/.748   | 3/4-16UNF   | 12    | 3.81  |
| HUBS516-A03     | 1.62  | 1.62 | 1.375/1.373 | .750/.748   | 3/4-16UNF   | 10    | 3.87  |
| HUBS517-A02     | 1.75  | 1.75 | 1.375/1.375 | 1.240/1.248 | 7/8-14UNF   | 10    | 3.65  |
| HUBS519         | 2.00  | 1.75 | 1.500/1.498 | 1.189/1.187 | 7/8-14UNF   | 10.5  | 5.28  |
| HUBS611-A04     | 2.00  | 1.75 | 1.500/1.498 | 1.250/1.248 | 1-14UNF     | 10    | 3.75  |
| HUBS611-A15     | 2.00  | 1.75 | 1.500/1.498 | 1.250/1.248 | 1-14UNF     | 12    | 4.06  |
| HUBS611-1-J-A04 | 1.75  | 1.62 | 1.495/1.493 | 1.250/1.248 | 1-14UNS     | 12.5  | 3.75  |
| HUBS614-A05     | 2.00  | 2.00 | 1.781/1.779 | 1.375/1.373 | 1-14UNS*    | 10    | 4.09  |
| HUBS614-A15     | 2.00  | 2.00 | 1.781/1.779 | 1.375/1.373 | 1-14UNS*    | 12    | 4.09  |
| HUBS618-A06     | 2.00  | 2.00 | 1.750/1.748 | 1.375/1.373 | 1-14UNS*    | 15    | 5.00  |
| HUBS618-A17     | 2.00  | 2.00 | 1.750/1.748 | 1.375/1.373 | 1-14UNS*    | 13    | 5.00  |
| HUBS630-A01     | 2.00  | 2.00 | 1.625/1.623 | 1.250/1.248 | 3/4-16UNF   | 11    | 5.15  |
| HUBS811-A03     | 2.125 | 2.00 | 1.796/1.794 | 1.375/1.373 | 1-14UNS     | 16    | 5.28  |
| HUBS812-A27     | 2.75  | 2.50 | 2.000/1.998 | 1.312/1.310 | 1-14UNS     | 14    | 5.46  |
| HUBS817-A03     | 3.00  | 3.00 | 2.250/2.248 | 1.625/1.623 | 1-1/4-12UNF | 16    | 6.436 |
| HUBS1010-A02    | 3.00  | 3.00 | 2.500/2.498 | 1.750/1.748 | 1-1/4-12UNF | 20    | 6.25  |
| HUBS1010-3-A23  | 4.00  | 3.37 | 2.750/2.748 | 1.750/1.748 | 1-1/4-12UNF | 22    | 6.25  |
| HUBS1020-A08FC  | 4.50  | 4.37 | 3.543/2.541 | 2.625/2.623 | 2-12UNF     | 22.87 | 8.25  |

## HUB ACCESSORIES

### Spindle Nuts

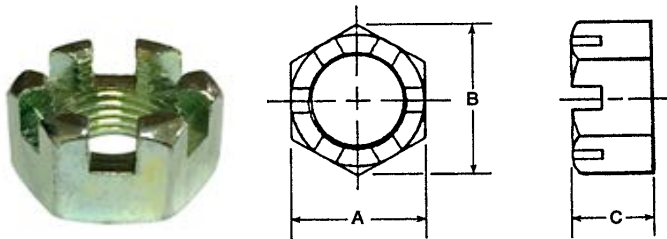

| NUT PART NO. | THREADS       | A       | B       | C      |
|--------------|---------------|---------|---------|--------|
| HUBWB29      | 5/8-18 UNF    | 15/16   | 1-1/16  | 35/64  |
| HUBWB30      | 3/4 - 16UNF   | 1-1/8   | 1-1/4   | 41/64  |
| HUBWB32      | 7/8 - 14UNF   | 1-5/16  | 1-1/2   | 3/4    |
| HUBWB33      | 1 - 14UNS     | 1-1/2   | 1-23/32 | 55/64  |
| HUBWB36      | 1-1/8-12 UNF  | 1-11/16 | 1-7/8   | 31/32  |
| HUBWB38      | 1-1/4 - 12UNF | 1-7/8   | 2-1/8   | 1-1/16 |

### Spindle Washers

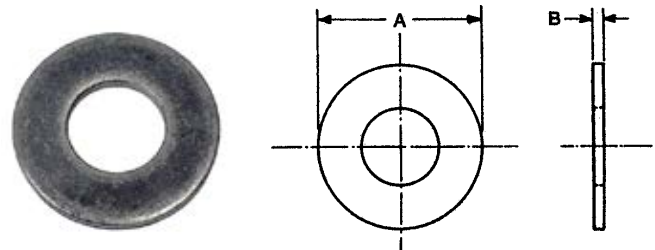

| WASHER PART NO. | SIZE  | A     | B    |
|-----------------|-------|-------|------|
| HUBWA10         | 3/4   | 1-3/4 | .119 |
| HUBWA12         | 7/8   | 2     | .187 |
| HUBWA17H        | 1     | 2     | .187 |
| HUBWA23         | 1-1/4 | 2-1/2 | .250 |

**HUB ACCESSORIES**

**Grease Seals**

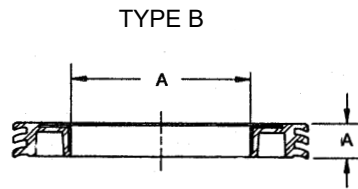
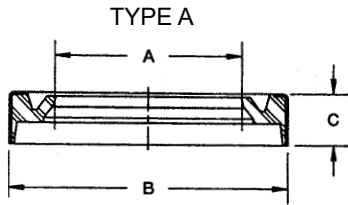

**SLEEVE\* SE33-01**

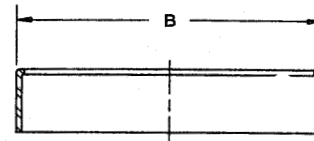

\*To be used with type B seal.



| SEAL NO. | TYPE | 'A' ID | 'B' OD | 'C' WIDTH |
|----------|------|--------|--------|-----------|
| HUBSE10  | A    | 1.21   | 1.983  | 0.406     |
| HUBSE11  | A    | 1.5    | 2.332  | 0.5       |
| HUBSE12  | A    | 1.62   | 2.332  | 0.438     |
| HUBSE13  | A    | 1.75   | 2.722  | 0.359     |
| HUBSE13X | A    | 1.75   | 2.754  | 0.35      |
| HUBSE14  | A    | 1.62   | 2.566  | 0.25      |
| HUBSE15  | A    | 1.37   | 2.332  | 0.41      |
| HUBSE16  | A    | 2      | 3.63   | 0.25      |
| HUBSE17  | A    | 2.5    | 3.881  | 0.469     |
| HUBSE18  | A    | 2.13   | 3.881  | 0.375     |
| HUBSE19  | A    | 1      | 1.785  | 0.469     |
| HUBSE22  | A    | 1.68   | 2.566  | 0.5       |
| HUBSE23  | A    | 2.29   | 3.153  | 0.359     |
| HUBSE24  | A    | 2.094  | 2.722  | 0.25      |
| HUBSE25  | A    | 2      | 3.066  | 0.375     |
| HUBSE26  | A    | 2.25   | 3.376  | 0.438     |
| HUBSE28  | A    | 1.5    | 2.627  | 0.25      |
| HUBSE29  | A    | 2      | 3.153  | 0.25      |
| HUBSE30  | A    | 2      | 3.548  | 0.469     |
| HUBSE31  | A    | 2.25   | 3.881  | 0.469     |
| HUB2762C | A    | 1.493  | 2.966  | 0.54      |
| HUB2763C | A    | 1.7    | 2.564  | 0.303     |
| HUB2764  | A    | 1.437  | 2.107  | 0.523     |

| SEAL NO.  | TYPE | 'A' ID | 'B' OD | 'C' WIDTH |
|-----------|------|--------|--------|-----------|
| HUBSE33   | B    | 1.5    | 2.566  | 0.29      |
| HUBSE35   | A    | 2.5    | 3.756  | 0.5       |
| SEA204506 | A    | 2      | 3.628  | 0.5       |
| HUBSE39   | B    | 1.62   | 2.566  | 0.29      |
| HUBSE40   | A    | 2.09   | 2.754  | 0.25      |
| HUBSE42   | A    | 3      | 4.008  | 0.438     |
| HUBSE44   | A    | 2      | 3.066  | 0.25      |
| HUBSE46   | A    | 1.87   | 3.005  | 0.25      |
| HUBSE48   | A    | 3      | 4.505  | 0.438     |
| HUBSE49   | **   | 4.25   | 6      | 0.062     |
| HUBSE55   | A    | 4.37   | 6.007  | 0.5       |
| HUBSE67   | A    | 3.375  | 4.625  | 0.438     |
| HUBSE77   | B    | 2.45   | 3.85   | 0.34      |

**Dust Caps**

| CAP NO. | TYPE | A     | B    | C    | D     |
|---------|------|-------|------|------|-------|
| HUBDC10 | A    | 1.79  | 1    | 0.25 | 0.039 |
| HUBDC11 | A    | 1.98  | 1.18 | 0.25 | 0.039 |
| HUBDC12 | A    | 1.94  | 1    | 0.25 | 0.039 |
| HUBDC13 | A    | 2.445 | 1.41 | 0.37 | 0.039 |
| HUBDC15 | A    | 2.721 | 1.45 | 0.37 | 0.047 |
| HUBDC17 | A    | 3.16  | 1.68 | 0.37 | 0.078 |
| HUBDC24 | A    | 1.956 | 0.96 | 0.34 | 0.039 |
| HUBDC26 | A    | 3.12  | 1.68 | 0.37 | 0.078 |
| HUBDC27 | B    | 5     | 2    | -    | 0.125 |
| HUBDC28 | B    | 5.5   | 2.62 | -    | 0.125 |

For Zinc Plated, add ZP to part number.

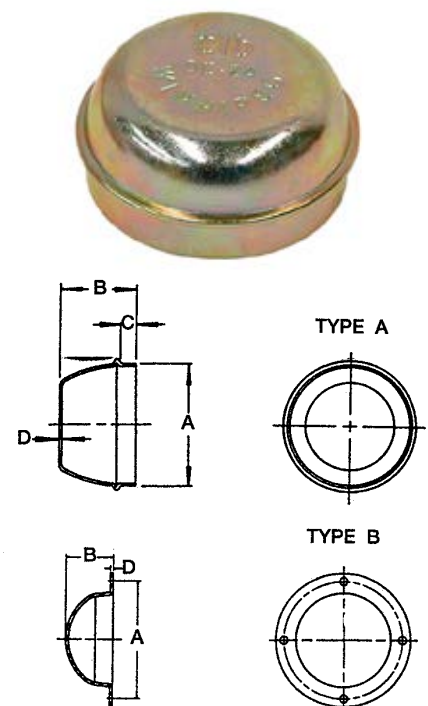

## HUB ACCESSORIES

### Wheel Bolts



| BOLT    | THREADS     | A     | B   | C   |
|---------|-------------|-------|-----|-----|
| HUBWB10 | 1/2-20 UNF  | 1-1/4 | 90° | 3/4 |
| HUBWB12 | 9/16-18 UNF | 1-1/4 | 90° | 7/8 |
| HUBWB17 | 9/16-18 UNF | 1-3/4 | 90° | 7/8 |
| HUBWB54 | 1/2-20 UNF  | 7/8   | 60° | 3/4 |
| HUBWB55 | 1/2-20 UNF  | 1     | 90° | 3/4 |

| STUD BOLT | THREADS     | A     | B     | C     |
|-----------|-------------|-------|-------|-------|
| HUBWB13   | 1/2-20 UNF  | 1-5/8 | 9/16  | 5/8   |
| HUBWB16   | 1/2-20 UNF  | 1-7/8 | 9/16  | 5/8   |
| HUBWB41   | 9/16-18 UNF | 2-1/4 | 5/8   | 5/8   |
| HUBWB46   | 5/8-18 UNF  | 2-1/2 | 9/16  | 11/16 |
| HUBWB51   | 3/4-16 UNF  | 2-5/8 | 3/4   | 1     |
| HUBWB102  | 3/4-16 UNF  | 3.282 | 3/4   | 1     |
| HUBWB136  | 7/8-16 UNF  | 3.50  | 13/16 | 1     |

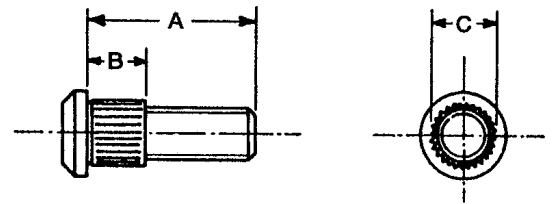
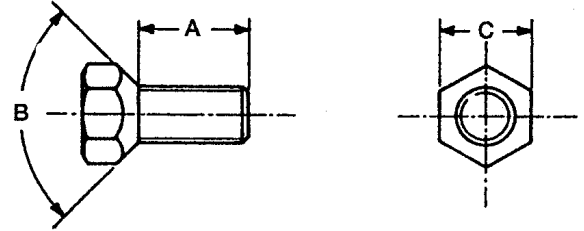

### Wheel Stud Nuts



| NUT     | THREADS     | A           | B     | C     |
|---------|-------------|-------------|-------|-------|
| HUBWB11 | 1/2-20 UNF  | 90°         | 5/8   | 13/16 |
| HUBWB18 | 5/8-18 UNF  | 90°         | 23/32 | 15/16 |
| HUBWB40 | 9/16-18 UNF | 90°         | 11/16 | 1     |
| HUBWB52 | 3/4-16 UNF  | Flange Nuts | 5/8   | 1 1/8 |
| HUBWB58 | 3/4-16 UNF  | Budd Nut    | 7/8   | 1 1/2 |

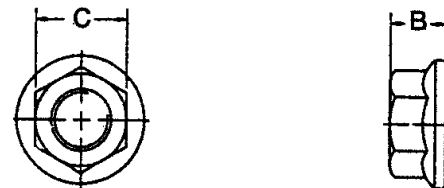
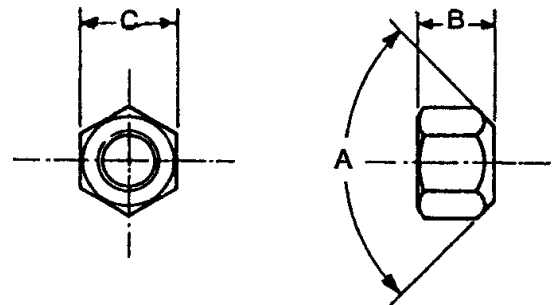

**SPECIAL HUBS**

**Special Hubs - Melroe Multiweeder (wings) & Ponycarts**

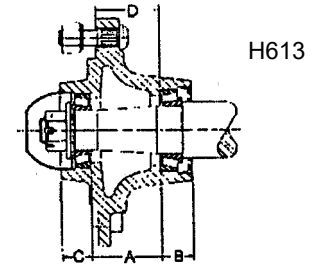

| HUB NO   | BEARING NO. |           |            |            |            |            | PART NO. |              |             | A                                   | B    | C    | D    | *CAP (lbs.) | SPINDLE  |
|--|-------------|-----------|------------|------------|------------|------------|----------|--------------|-------------|-------------------------------------|------|------|------|-------------|----------|
|  | INNER CUP   | OUTER CUP | INNER CONE | INNER BORE | OUTER CONE | OUTER BORE | DUST CAP | WHEEL BOLT   | GREASE SEAL |                                     |      |      |      |             |          |
| Hubs to fit Melroe Multiweeder (wings) and Ponycarts |             |           |            |            |            |            |          |              |             | 4 BOLT, 5" BOLT CIRCLE, 3.62" PILOT |      |      |      |             |          |
| HUBH613  | LM29710     | LM67010   | LM29749    | 1.50       | LM67048    | 1.25       | DC13     | WB16<br>WB11 | SE13        | 2.18                                | 1.00 | 0.93 | 2.00 | 3600        | S613-A01 |

Hubs include parts in shaded areas only.

**Special Hubs - Versatile Drills**

**5 BOLT, 5.50" BOLT CIRCLE, 4" PILOT**

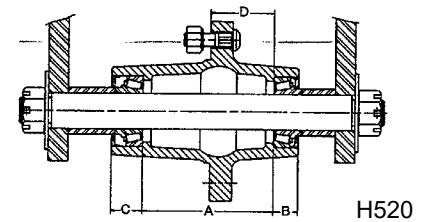

| HUB NO   | BEARING NO. |           |            |            |            |            | PART NO. |              |             | A    | B   | C    | D    | *CAP (lbs.) |
|----------|-------------|-----------|------------|------------|------------|------------|----------|--------------|-------------|------|-----|------|------|-------------|
|          | INNER CUP   | OUTER CUP | INNER CONE | INNER BORE | OUTER CONE | OUTER BORE | DUST CAP | WHEEL BOLT   | GREASE SEAL |      |     |      |      |             |
| HUBH520* | 14276       | 14276     | 14136A     | 1.37       | 14136A     | 1.37       | -        | WB16<br>WB11 | SE13        | 5.00 | 1.0 | 1.00 | 2.43 | 5700        |

\*Hub available with bolts in lieu of studs. Hubs include parts in shaded areas only.

**Special Hubs - Concord**

**6 BOLT, 6" BOLT CIRCLE, 4.62" PILOT**

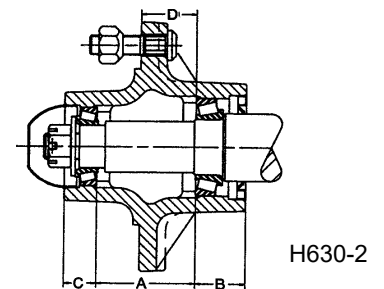

| HUB NO    | BEARING NO. |           |            |            |            |            | PART NO. |              |             | A    | B    | C   | D    | *CAP (lbs.) |
|-----------|-------------|-----------|------------|------------|------------|------------|----------|--------------|-------------|------|------|-----|------|-------------|
|           | INNER CUP   | OUTER CUP | INNER CONE | INNER BORE | OUTER CONE | OUTER BORE | DUST CAP | WHEEL BOLT   | GREASE SEAL |      |      |     |      |             |
| HUBH630-2 | LM501310    | LM67010   | LM501349   | 1.62       | LM67048    | 1.25       | DC13     | WB41<br>WB40 | SE63        | 2.84 | 1.43 | .93 | 1.59 | 3500        |

Note: Hubs include parts in shaded areas only.

## SPECIAL HUBS

### Special Hubs - Morris, Flexicoil (Air Seeders)

**10 BOLT, 11.25" BOLT CIRCLE, 8.69" PILOT**

H1010

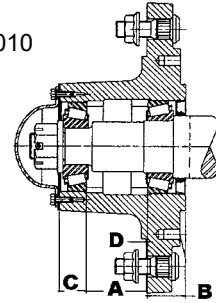

| HUB ORDER NO | BEARING NO. |           |            |            |            |            | PART NO. |              |             | A    | B    | C    | D    | *CAP (lbs.) |
|--------------|-------------|-----------|------------|------------|------------|------------|----------|--------------|-------------|------|------|------|------|-------------|
|              | INNER CUP   | OUTER CUP | INNER CONE | INNER BORE | OUTER CONE | OUTER BORE | DUST CAP | WHEEL BOLT   | GREASE SEAL |      |      |      |      |             |
| HUBH1010-13  | 39520       | 453A      | 39585      | 2.50       | 460        | 1.75       | DC27     | WB51<br>WB52 | SE48        | 2.81 | 1.75 | 1.25 | 0.06 | 12,000      |

## CASTERS

### 4000 Series Algood Casters

Excellent for general to medium duty usage, hardware, factory, warehouses.  
Economical without sacrificing durability.

#### FEATURES

- Kingpin: 1/4", 3/8", 3/8", 3/8", 7/16" diameter rivet
- Raceway: 1/8", 3/16", 7/32", 7/32", 5/16" diameter upper race; hardened steel load bearings
- Bushing: Nylon, steel, roller and ball bearing (BB available on some applications)
- Axle & Nut: 3/16" rivet, 1/4", 5/16", 3/8" axle and lock nut
- Finish: Corrosion resistant bright zinc finish
- Special: Large single raceway deeply embossed for extra strength.

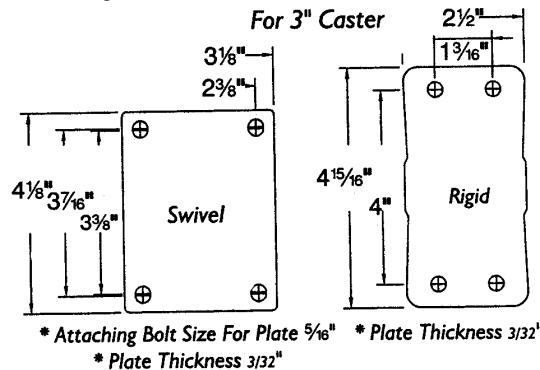

| DIAMETER | WHEEL       |              |               | CASTER        |                |             | PART NO. |                 |
|----------|-------------|--------------|---------------|---------------|----------------|-------------|----------|-----------------|
|          | TREAD WIDTH | BEARING TYPE | CAPACITY lbs. | SWIVEL RADIUS | OVERALL HEIGHT | WHEEL TYPE  | SWIVEL   | RIGID           |
| 3"       | 1 1/4"      | Nylon        | 250           | 2 7/8"        | 3 3/4"         | Soft Rubber | -        | HUBR4003-125-SR |

**COMPLETE UTILITY WHEELS**

**Light Duty Wheels**

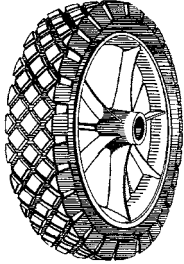

Diamond Plastic

**Plastic Light Duty Wheels**

| PART NO.     | SIZE     | HUB        | BORE | TREAD   | EST. CAPACITY | WEIGHT |
|--------------|----------|------------|------|---------|---------------|--------|
| HUB6150P-1/2 | 6 x 1.50 | 1 3/8" Off | 1/2" | Diamond | 50            | 1      |

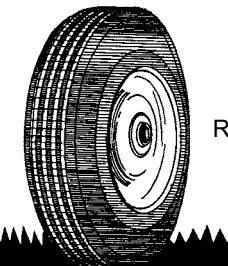

Rib

**Steel Light Duty Wheels**

Used on many lawn furniture, cart, wagon, light duty hand truck, barbeque grill, trash container, golf cart, rotary mower and toy applications.

| PART NO.       | SIZE      | HUB         | BORE    | TREAD | EST. CAPACITY | WEIGHT |
|----------------|-----------|-------------|---------|-------|---------------|--------|
| HUB6150BB-1/2  | 6 x 1.50  | 1 3/4" CTD  | 1/2" BB | Rib   | 50            | 1 1/4  |
| HUB8175BB-1/2  | 8 x 1.50  | 2" CTD      | 1/2" BB | Rib   | 60            | 2 1/2  |
| HUB10175BB-1/2 | 10 x 1.75 | 2 1/16" CTD | 1/2" BB | Rib   | 80            | 3 1/4  |

**Flat Free Universal Tire & Wheel**

- Foam filled, never goes flat.
- Retains pneumatic-like feel, not hard as a rock.
- Standard sizing 4.80/400 x 8
- 4-ply rating
- 4" width of wheel shaft, 3/4" I.D. bearing



| PART NO.     | DESCRIPTION                        |
|--------------|------------------------------------|
| HUB400X8A-FF | Flat free universal tire and wheel |

**Low Speed Wheel Assembly**

- 480/400 x 8
- 4-ply rating
- 4" width of wheel shaft, 3/4" I.D. bearing
- Multi use wheel assembly
- Sprayer booms
- Wheel barrows
- Carts
- Portable equipment



| PART NO.    | DESCRIPTION                          |
|-------------|--------------------------------------|
| HUB400X8A   | Low speed wheel assembly, air filled |
| BEIASF107-6 | Replacement bearing for HUB400X8A    |

**See Ag Catalogue Section 19 for Jacks & Jack Repair Parts**